



SINOCERA



Global Sensor Technology

Piezoelectric Accelerometer (Isolated)

Model: CA-YD-187C01

Features

- Built-in IEPE, low noise, strong resistance of disturbance
- Isolated, Floating, industrial site monitoring
- Side 2-pin MIL-C-5015 two-pin socket output.



Specifications:

Sensitivity (20±5°C)	100 mV/g
Measurement Range (pk)	±50 g
Max Transverse Sensitivity	<5%
Frequency Response (±10%)	1~7,000 Hz
(±3dB)	0.5~10,000 Hz
Amplitude linearity	≤1%
Operating Temp. Range	-40~+120 °C
Temperature Response	See Graph
Shock Limit (pk)	2000 g
Noise (rms)	<50 μV
Output Impedance	<100 Ω
Operating Voltage (Constant current source)	+18~28 VDC
Operating Current	2~10 mA
DC Bias Voltage	11±1.5 VDC
Case Isolation	≥10 ⁸ Ω
Mounting	φ6.4 Through Hole
Sensing Element	Piezoelectric Ceramics
Sensing Geometry	Shear
Case Material	304 Stainless steel
Sealing	IP65
Weight	73 g
Output	Side 5/8-24 2-pin Socket
Accessories	
Certificate	Calibration parameters
1/4-28 Stud	one
3106A (5015) Plug, Cable (RVVP)	one (3m), one end free

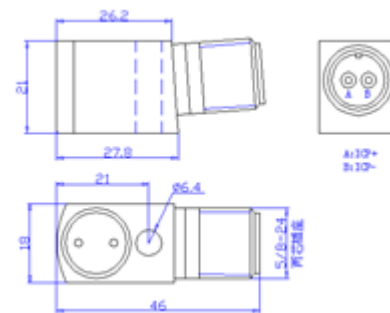

Dimensions

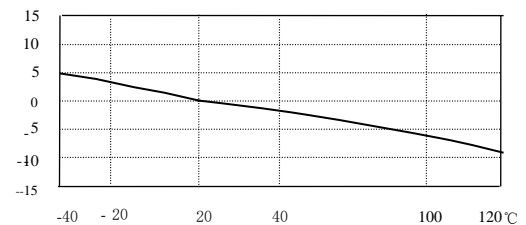

Temperature Response

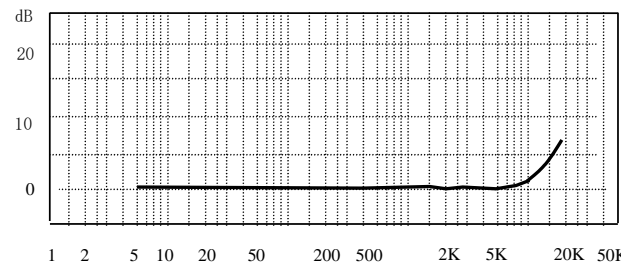

Frequency Response